

# SM-HYPONIC®

## Hypoid Right Angle Gearmotor

Operating and Maintenance Manual



*THE  
AVAILABLE  
SOLUTION,  
WORLDWIDE.*



Manual

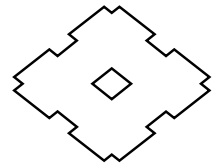
07.020.60.001

# TABLE OF CONTENTS

---

Mounting . . . . .	1-3	FB Brake Assembly – Inspection, Adjustment, and Maintenance . . . . .	8-13
Solid Shaft Type . . . . .	1	Brake Models FB-01A, FB-02A and FB-05A . . . . .	8-9
Hollow Shaft Type . . . . .	1-3	Brake Models FB-1B, FB-2B and FB-3B . . . . .	9-11
Connecting to the Driven Machine . . . . .	3	Brake Models FB-5B and FB-8B . . . . .	11-13
Wiring . . . . .	4-6	Troubleshooting . . . . .	13-15
Standard Wiring, Dual Voltage . . . . .	4	Construction . . . . .	16
Inverter Wiring, Dual Voltage . . . . .	5-6		
Lubrication . . . . .	7		
Operation . . . . .	7		
Daily Inspection and Maintenance . . . . .	7		

# MOUNTING



## Solid Shaft Type

### 1. Mounting conditions

- Ambient temperature: 14°F ~ 104°F
- Humidity: 85% or less
- Altitude: Lower than 3300 ft (1000 m) above sea level
- Atmosphere: Free from corrosive gases, explosive gases or steam. It should also be free from dust and well ventilated.
- Location: Indoors

2. Mount the gearmotor on a rigid surface.
3. There is no restriction for mounting angle.
4. Use hexagon socket head bolts when mounting RNFM series (flange-mount type). See **Table 1** for bolt sizes.

**Table 1**

Series	Frame Size	Size of hexagon socket head bolt
RNFM	20", 23"	M8
	30", 33"	M10
	40", 43"	M10
	50", 53", 54"	M12

## Hollow Shaft Type

### 1. Mounting conditions

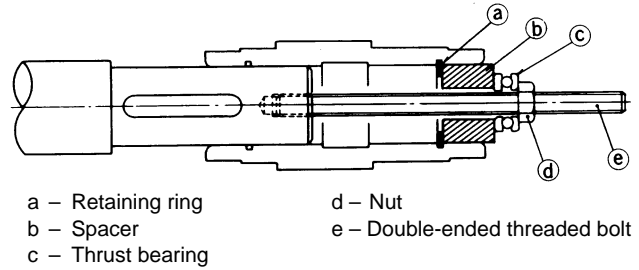
- Ambient temperature: 14°F ~ 104°F
- Humidity: 85% or less
- Altitude: Less than 3300 ft (1000 m) above sea level
- Atmosphere: Free from corrosive gases, explosive gases, steam and dust. It should also be well ventilated.
- Location: Indoors

2. Mount the gearmotor on a driven shaft that has sufficient rigidity.
3. There is no restriction for the mounting angle.
4. Mounting Procedures

#### a. Connecting a Driven Shaft

Apply molybdenum disulfide grease to the surface of the shaft and the inner surface of the hollow shaft. Slide the SM-Hyponic onto the shaft. To make the installation smoother if the fit is too tight, lightly tap the end of the hollow output shaft with a wooden hammer. **Avoid hitting the casing.** To ensure smooth installation of the drive, we recommend the use of a jig shown in Fig. 1.

**Fig. 1**

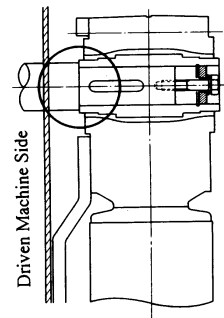


- a – Retaining ring
- b – Spacer
- c – Thrust bearing
- d – Nut
- e – Double-ended threaded bolt

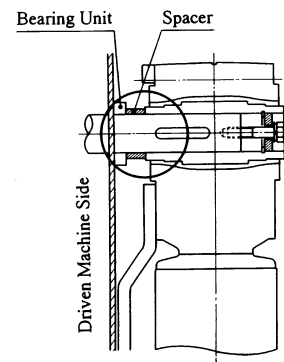
The hollow shaft is made according to ISO H8 tolerances. Following installation, ensure that the fitting between the hollow and the driven shaft is tightened correctly. We recommend ISO js6 or k6 as the tolerance for the driven shaft.

### b. Mounting the SM-Hyponic gearmotor

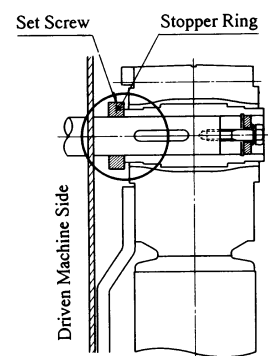
**Fig. 2 Stepped Shaft Option**



**Fig. 3 Spacer Option**

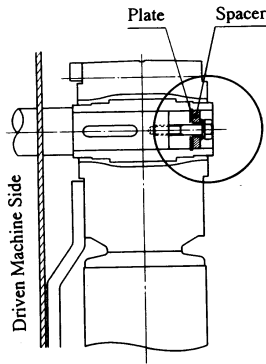


**Fig. 4 Set Screw Option**

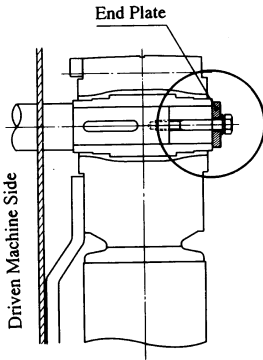


# MOUNTING

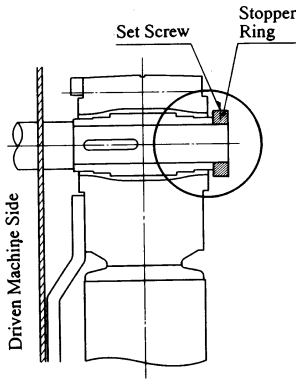
**Fig. 5 Spacer and Plate Option**



**Fig. 6 End Plate Option**

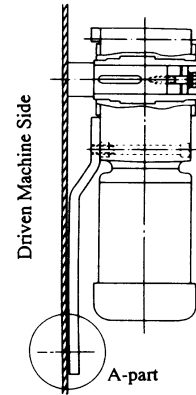


**Fig. 7 Set Screw and Stopper Ring Option**

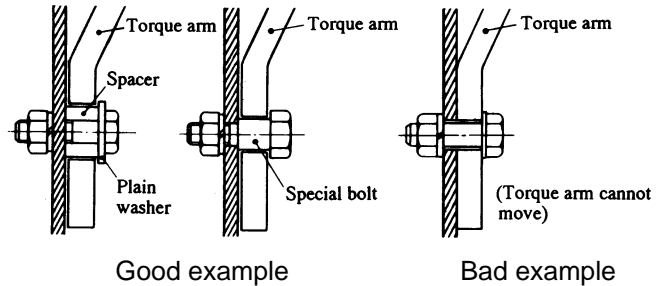


The torque arm (Section A in Fig. 8) should be mounted to ensure that the contact surface between the drive and shaft are free from excessive forces. **Do not attach the torque arm using anti-rotation bolts.**

For applications that require frequent starts and stops or frequent reversing, insert a rubber bushing between the torque arm and securing bolt (or spacer) in order to dampen impact load.



**Fig. 8 Torque Arm Securing Methods**

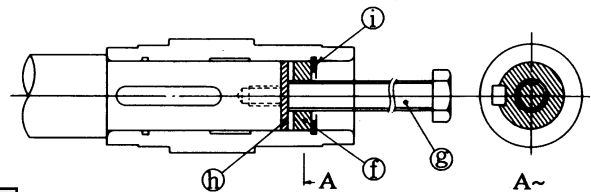


(d) Removing the shaft.

Do not apply excessive force to the gearmotor and shaft. Using a jig as shown in Fig. 9 will facilitate removal of the shaft.

Note: The customer should prepare parts for setting, securing or removing the shaft.

**Fig. 9**



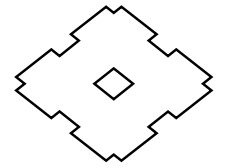
f – Spacer  
h – Plate  
g – Bolt  
i – Shaft retaining C-ring

(c) Installing the torque arm.

Mount the torque arm on the driven machine side of the drive casing. Use hexagon socket head bolts for mounting. (See Table 2 for bolt sizes.)

**Table 2**

Series	Frame Size	Size of hexagon socket head bolt
RNFM	20, 23	M8
	30, 33	M10
	40", 43"	M10
	50", 53", 54"	M12
	60, 63, 64	M20

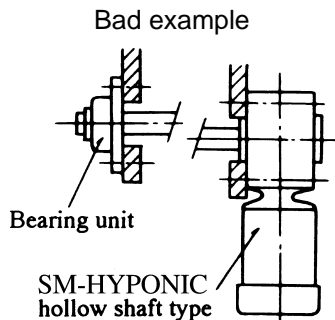
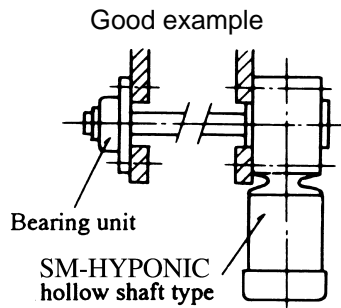


# MOUNTING

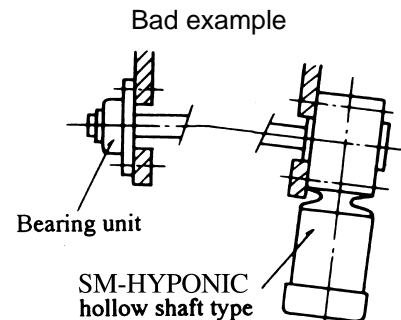
## (5) Flange and Foot Mounting (optional).

When installing the SM-Hyponic, ensure that the gearmotor and the shaft of the driven machine are properly aligned so that the drive is free from excessive force.

**Fig. 10 Flange coupling**

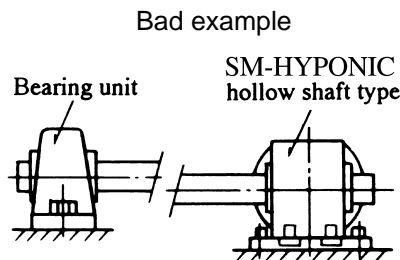
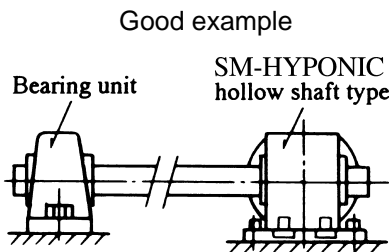


(The concentricity between the shaft and mounting pilot is out of allowable range.)

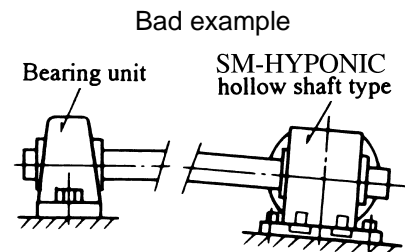


(The shaft centerline is not positioned at right angles to the flange.)

**Fig. 11 Foot mounting (optional)**



(The shaft center of the bearing unit does not align with that of the Drive.)



(The parallelism of the mounting beds is out of allowable range.)

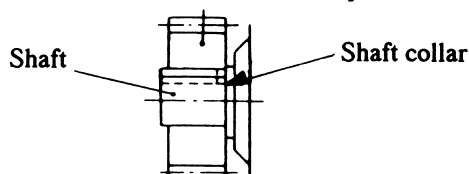
# CONNECTING TO THE DRIVEN MACHINE

## Solid-shaft type

1. Mount the connecting device, such as a coupling, chain, sprocket, gear or V-pulley, on the shaft as close as possible to the shaft collar. This places the load point between the center of the shaft and the shaft collar.
2. We recommend using end cap screws to avoid possible bearing damage from excessive force or thrust load that may be applied to the shaft while fitting the connecting device.
3. When connecting the SM-Hyponic gearmotor to the driven machine, be sure to align the shafts of both units (for coupling connection) or keep both shafts parallel (for chain, gear or V-belt connection).
4. Excessively loose chains will cause a jolt upon start-up that may damage the SM-Hyponic gearmotor and the driven machine. Excessive tension of V-belts may cause bearing failure.

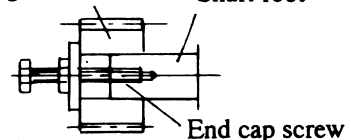
**Fig. 12**

Gear, chain, sprocket



**Fig. 13**

Connecting device  
Shaft foot



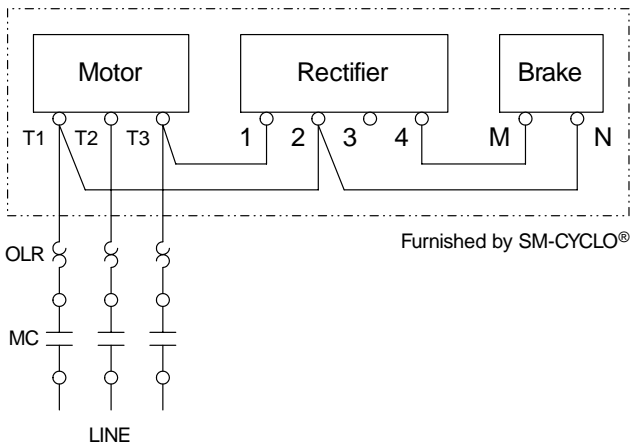
# WIRING

1. Prior to wiring, refer to the name plate mounted to the motor portion of the SM-Hyponic gearmotor. Check the power supply, interconnects, relays, protective starting devices (i.e., Star (Wye) delta – if reduced voltage starting is required), space heaters, thermal sensors and other accessories.
2. Be aware that long wiring may cause voltage drops.

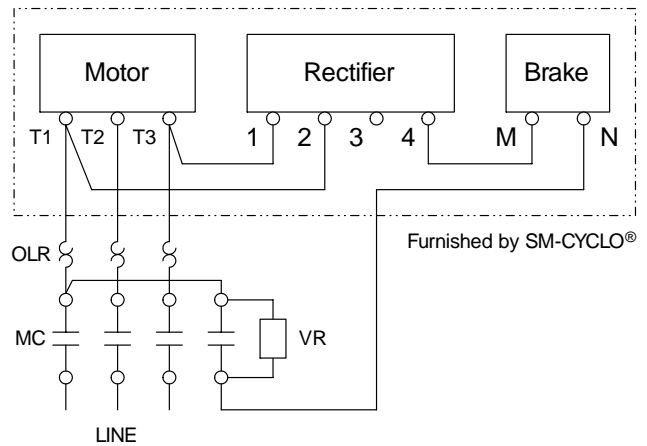
3. Figures 14a – d show standard specifications for wire connections and terminal marks. Figures 15a – d show specifications for inverter connections. Figure 16 shows the rotating direction of the output shaft when using wiring connections shown in Figures 14a – d. Table 3 lists Brake lining size specifications and Table 4 lists Varistor Specifications.

## Standard Wiring Connection, Dual Voltage

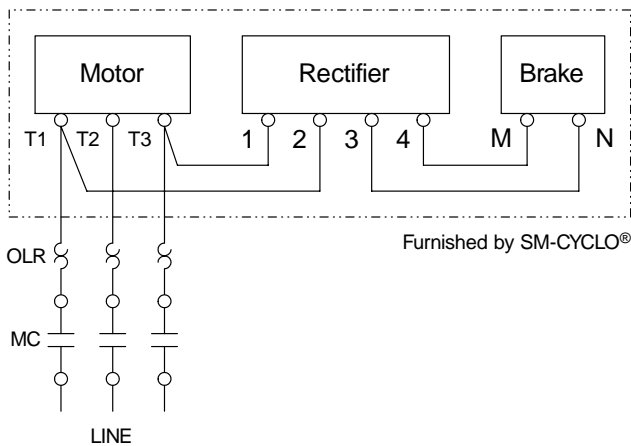
**Fig. 14-a Normal Brake Action, High Voltage**



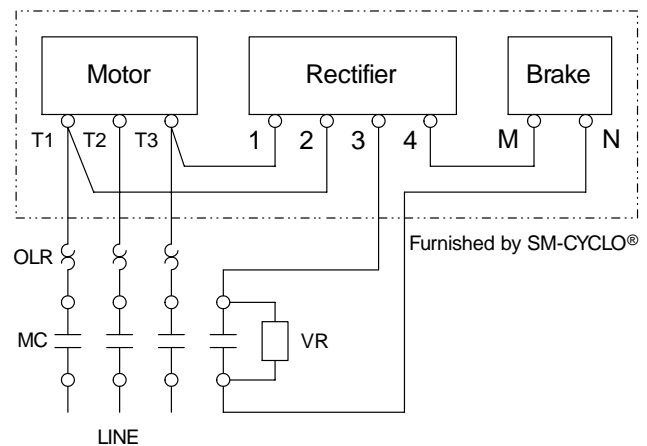
**Fig. 14-b Fast Brake Action, High Voltage**

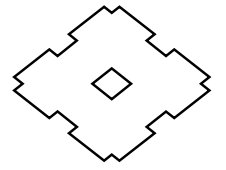


**Fig. 14-c Normal Brake Action, Low Voltage**



**Fig. 14-d Fast Brake Action, Low Voltage**



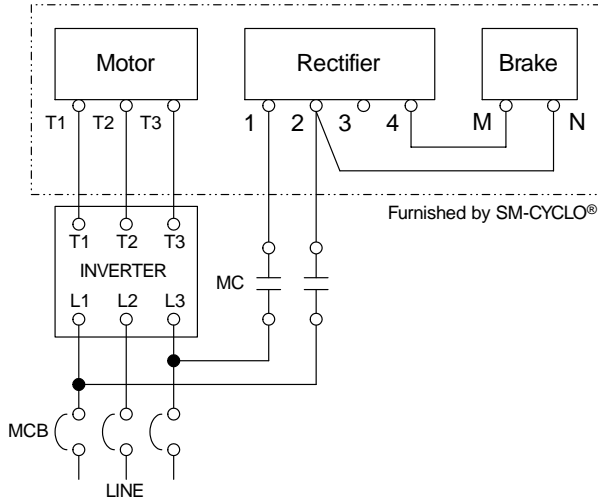


## Inverter Wiring Connection, Dual Voltage

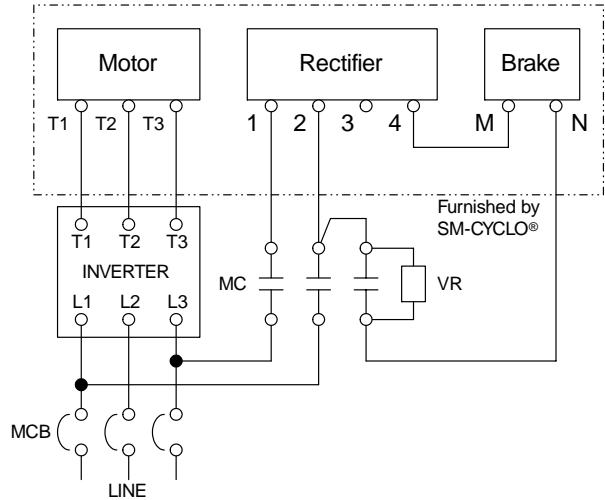
Symbols

- MC: Electromagnetic contactor
- MCB: Magnetic circuit breaker
- OLR: Overload or thermal relay
- VR: Varistor (protective device)

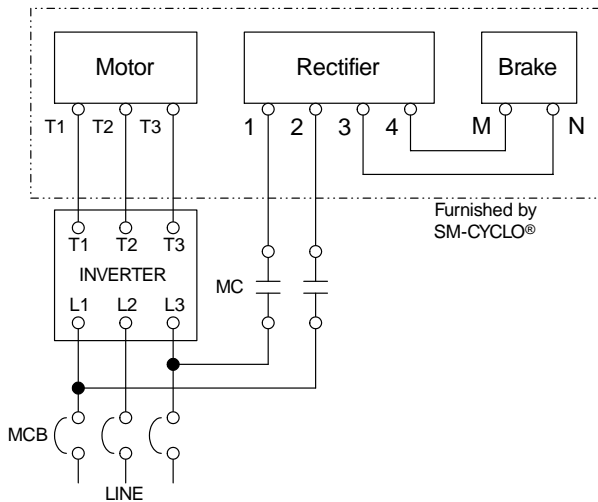
**Fig. 15-a Normal Brake Action, High Voltage**



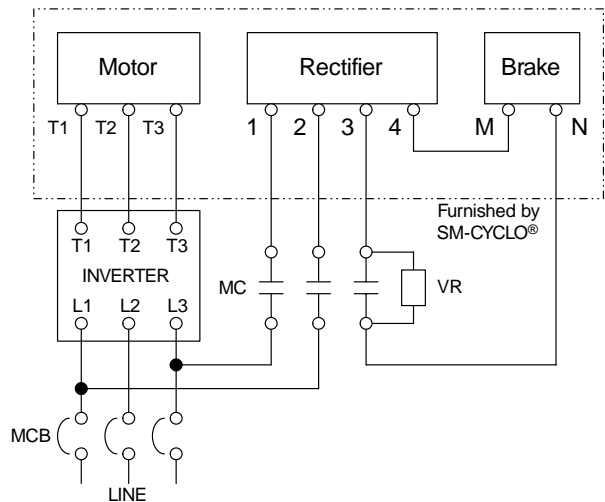
**Fig. 15-b Fast Brake Action, High Voltage**



**Fig. 15-c Normal Brake Action, Low Voltage**



**Fig. 15-d Fast Brake Action, Low Voltage**



**Note:** Recommended brake contactor size for fast acting circuit is greater than 5 times the rated current shown in Table 8 on page 8.

**Table 4 Varistor Specifications**

Operating Voltage		200-230V	380-460V
Var. Rated Voltage		AC260~300V	AC510V
Varistor Voltage		430~470V	820V
Rated	FB-01A, 02A	Over 0.2W	Over 0.4W
Watt	FB-05A	Over 0.2W	Over 0.4W

# WIRING

**Fig. 16 Rotating Direction of the Output Shaft**

If wiring connection has been completed as shown in Fig. 14, a motor shaft rotates clockwise as seen from the fan cover side. The rotating directions of an output shaft are indicated by arrows in Table below.

kW	HP	Frame Size	Speed ratio	kW	HP	Frame Size	Speed reduction ratio
0.1	1/4	20	10 • 12 • 15 • 20 • 25 • 30 • 40 • 50 • 60	0.1	1/4	20	80 • 100 • 120
0.2	1/3	23	10 • 12 • 15 • 20 • 25 • 30	0.2	1/3	23	40 • 50 • 60
		30	10 • 15 • 20 • 30 • 40 • 50 • 60			30	80 • 100 • 120
0.4	1/2	33	10 • 12 • 15 • 20 • 25 • 30	0.4	1/2	33	40 • 50 • 60
		40	10 • 15 • 20 • 30 • 40 • 50 • 60			40	80 • 100 • 120
0.75	3/4 1	43	10 • 12 • 15 • 20 • 25 • 30	0.75	3/4 1	43	40 • 50 • 60
		50	10 • 15 • 20 • 30 • 40 • 50 • 60			50	80 • 100 • 120
1.5	1.5 2	53	10 • 12 • 15 • 20 • 25 • 30	1.5	1.5 2	53	40 • 50 • 60 • 80
		60				60	80 • 100 • 120
2.2	3	54	10 • 12 • 15 • 20 • 25 • 30	2.2	3	54	40 • 50 • 60
		60	10 • 12 • 15 • 20 • 25 • 30 • 40 • 50			60	60 • 80
3.7	5	63	10 • 12 • 15 • 20 • 25 • 30	3.7	5	63	40 • 50
5.5	7½	64	10 • 12 • 15 • 20 • 25	5.5	7½	64	30

Series	Configuration	Rotating Direction
RNFM series	R type	Clockwise
	L type	Counter-clockwise
RNHM series	R type	Clockwise
	L type	Counter-clockwise
	T type	Clockwise
RNYM series	Configuration	Clockwise

**Note:** Replacing two of the three power supplies of a three-phase induction motor will cause the motor to rotate in directions reverse to those shown in above Figure. Also replacing X with Y of single-phase induction motor will cause the motor to rotate in directions reverse to those shown in above Figure.

**4. Motor Operation Precautions**

- a. **Always ground the motor terminal box or frame.**
- b. Insulation resistance

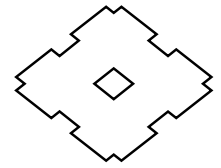
Determine the insulation resistance (to do this, separate the motor and the control board). The insulation resistance value will vary depending on the temperature, humidity, extent of contamination, the servicing period, test running

time, as well as the motor output, voltage and type of insulation. Therefore, the insulation resistance (r) cannot be expressed uniformly; however, it should be equal to or greater than the value listed in Table 5.

**Table 5 Insulation Resistance**

Motor voltage	Mega voltage	Insulation resistance (R)
Low voltage motor (Lower than 600V)	500V	Higher than 1 M Ω





# LUBRICATION

1. SM-Hyponic gearmotors are grease-lubricated. They are filled prior to shipment and arrive ready for customer use.
2. Ensure that the connection to the driven machine is correct.
3. Ensure that the rotation direction is correct.
4. After completing these steps, start the test run, without any load, and increase the load gradually. Also observe the precautions listed in Table 6.

# OPERATION

Once the SM-Hyponic gearmotor is installed, ensure that the wiring is correct and secure prior to operation. Observe the precautions listed in Table 6 during the trial run. Stop running the gearmotor if any abnormalities are detected and contact your nearest sales office or distributor.

**Table 6 Trial Run Precautions**

Observation	Possible Cause
Any abnormal noises or vibrations.	(1) The casing is distorted due to an uneven mounting surface. (2) The gearmotor is resonant due to insufficient rigidity of the mounting surface. (3) The shaft of the SM-Hyponic and the driven machine are not aligned. (4) Vibrations of the driven machine are conveyed to the gearmotor. (5) Rigidity of the driven machine and its shaft is insufficient (hollow shaft type). (6) Excessive force is exerted on the baffle sections of the torque arm (hollow shaft type). (7) After the SM-Hyponic gearmotor is flange or foot mounted, undue force is exerted between the gearmotor and its shaft.
Abnormally high temperature of the gear casing or motor frame surface.	(1) The electric current is exceeding the rated value specified on the nameplate. (2) The rise and fall of the electric current is too intense. (3) The ambient temperature of the gearmotor is too high.

# DAILY INSPECTION AND MAINTENANCE

1. Inspect the gearmotor daily for each of the items listed in Table 7.
2. If any abnormalities are found during daily inspections, follow the procedures outlined in the Troubleshooting Guide, Table 20 on page 14. If the abnormality is not listed or the recommended procedure does not solve the problem, contact your nearest sales office or distributor.
3. The SM-Hyponic gearmotor does not require grease replenishment, but overhauling after 10,000 hours of operation, or 2 – 3 years will extend its life. Note: Over-hauling consists of disassembling the unit, replacing the seals and gaskets, cleaning the internal parts and then repacking the unit with designated grease.

**Table 7 Daily Inspection Items**

Items	Details
Electric current	Is the electric current higher than the value specified on the nameplate?
Noise	Is the gearmotor making any unusual noises?
Vibration	Are there any unusual vibrations of the gear case or motor frame?
Surface temperature	Is the surface temperature of the gear case, or motor frame not too high or rising suddenly? (The temperature rise during operation varies depending on the type of motor. There may be a problem, if the temperature frequently rises approximately 40°C (104°F) above the ambient temperature.)
Grease leakage	Is there any grease leaking from the gear assembly?
Mounting bolts	Are there any loose mounting bolts?
Chains and V-belts	Are there any loose chains or V-belts?
Brake	Is the brake lining worn out?

# FB BRAKE ASSEMBLY – INSPECTION, ADJUSTMENT & MAINTENANCE

SM-Cyclo FB series brakemotors are designed to be mechanically rugged, electrically reliable and efficient in operation. To maintain this reliable performance, the brake assembly must be inspected and adjusted periodically.

This section of the manual pertains specifically to the brake portion of the SM-Hyponic gearmotor and provides all the necessary information to insure long and trouble-free service.

## Brake Models FB-01A, FB-02A and FB-05A

### 1. Standard Brakemotor Specifications

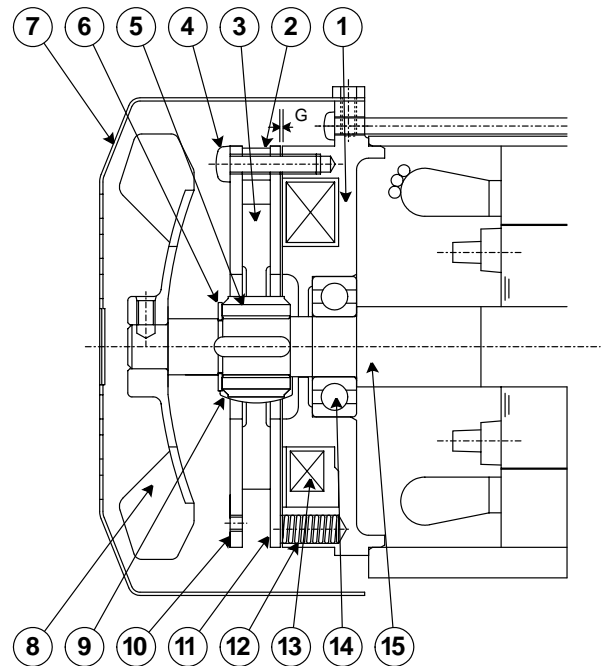
Table 8 lists the standard specifications for Models FB-01A, FB-02A and FB-05A.

**Table 8 Models FB-01A, FB-02A, FB-05A Standard Specifications**

Brake Type	Motor HP	Brake Torque ft-lb	Inertia WK <sup>2</sup> lb-ft <sup>2</sup>	Brake Coil	Brake Current (A)		Coil Resis ohms	Brake Delay Time (seconds)	
					230V	460V		Normal	Fast
FB-01A	1/8	0.7	0.0083	DC Energized Type, Built-in Rectifier within Conduit Box	0.1	0.06	2700	0.15 ~ 0.2	0.015 ~ 0.02
FB-02A	1/4 1/3	1.4	0.0131		0.1	0.06	1791	0.15 ~ 0.2	0.015 ~ 0.02
FB-05A	1/2	2.9	0.016		0.1	0.06	1791	0.1 ~ 0.15	0.01 ~ 0.015

Notes: 1) Continuous time rating for both the brake and motor.  
2) Indoor types can be installed for use in any orientation.

**Fig. 17 FB-01A, FB-02A, FB-05A Models**



### 2. Construction and Operating Principles

#### a. Construction

Fig. 17 illustrates the construction of the brake. The restraining bolt (4) fastens the brake shoe (10) and spacer (2) onto the stationary core (1). The armature plate (11) is kept from rotation by the restraining bolt (4) but moves axially by electromagnetic attraction and the tension of the pressure spring (12). The brake lining (3) is fitted to the hub (5), which is secured to the motor shaft with a key. The solenoid coil (13) is energized via a rectifier located within the conduit box.

#### b. Operating Principles

The brake is a (fail-safe type) spring actuated type brake that releases the brake mechanism when the solenoid coil is energized and engages when the solenoid coil is not energized.

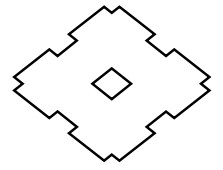
When power is applied to the unit, the solenoid coil and electric motor become energized and the energized coil attracts the armature plate (11) against the tension of the pressure spring (12). As a result, the brake lining (3) disengages and the motor starts to run.

When the power is disconnected, the solenoid coil and electric motor are not energized. This causes the pressure spring (12) to actuate the armature plate (11), which in turn presses the brake lining (3) against the brakeshoe (10) and brings the motor to a quick stop.

**Table 9 FB-01A, -02A, -05A Parts**

No.	Part Name	No.	Part Name
1	Stationary Core*	9	Leaf Spring*
2	Spacer*	10	Brake Shoe*
3	Brake Lining*	11	Armature*
4	Restraining Bolt*	12	Pressure Spring*
5	Hub*	13	Solenoid Coil*
6	C-type Retaining Ring	14	Ball Bearing
7	Cover	15	Motor Shaft
8	Fan (TEFC model only)		

\*These parts are included in a complete brake kit.



### 3. Inspection

At regular intervals, check that:

- a. the unit is operating normally.
- b. the brake lining is not excessively worn (or gap G is normal).
- c. all the mounting screws are securely tightened.

### 4. Gap Inspection

The brake lining will wear after the unit has been used for a long period of time. Regularly check that gap G (Fig. 17) is at an acceptable value. If gap G becomes too large, the solenoid coil may fail to pull in the armature plate, and hence cannot release the brake, resulting in the unit remaining in a continuously braked condition. Follow these steps to inspect the brake gap:

- a. Remove the cover (7).
- b. Insert a gap gage into the space between the stationary core (1) and armature plate (11). Measure the gap size at three appropriate circumferential points.
- c. The gap needs to be adjusted if the values are close to the allowable limit listed in Table 10.

**Table 10 Brake Gap Size**

Brake Type	Gap value G (in)	
	Spec. value	Allowable limit
FB-01A	0.006 ~ 0.010	0.020
FB-02A		
FB-05A		

### 5. Gap Adjustment

If the brake lining is so heavily worn that gap adjustment is required, follow these steps:

- a. Remove the cover (7).
- b. Loosen the restraining bolt (4), rotate the brake shoe one complete turn counterclockwise and retighten the restraining bolt (4). After tightening the restraining bolt, measure the gap G to verify that it falls between the specification value and the allowable limit shown in Table 10. (This procedure reduces the gap approximately 0.012 inch.)
- c. Turn the system power on and off a few times to check the brake performance.
- d. Replace the cover (7).

**Table 11 Brake Lining Size**

Brake Type	Brake lining dimension	Initial thickness $t_0$ (in)
FB-01A		0.276
FB-02A		
FB-05A		

## Brake Models FB-1B, FB-2B and FB-3B

### 1. Standard Brakemotor Specifications

Table 12 lists the standard specifications for Models FB-1B, FB-2B and FB-3B.

**Table 12 Models FB-1B, FB-2B, FB-3B Standard Specifications**

Brake Type	Motor HP	Brake Torque ft-lb	Inertia WK <sup>2</sup> lb-ft <sup>2</sup>	Brake Coil	Brake Current (A)		Coil Resis ohms	Brake Delay Time (seconds)	
					230V	460V		Normal	Fast
FB-1B	3/4 1	5.8 5.8	0.0267 0.0308	DC Energized Type, Built-in Rectifier within Conduit Box	0.1	0.06	1470	0.2 ~ 0.3	0.01 ~ 0.02
FB-2B	1.5 2	11 11	0.0504 0.0558		0.3	0.2	589	0.2 ~ 0.3	0.01 ~ 0.02
FB-3B	3	16	0.0884		0.3	0.2	589	0.3 ~ 0.40	0.01 ~ 0.02

Notes: 1) Continuous time rating for both the brake and motor.  
2) Indoor types can be installed for use in any orientation.

# FB BRAKE ASSEMBLY – INSPECTION, ADJUSTMENT & MAINTENANCE

## 2. Construction and Operating Principles

### a. Construction

Fig. 17 illustrates the construction of the brake. The restraining bolt (7) fastens the brake shoe (15), gap adjusting shim (5) and spacer (4) onto the stationary core (1). The restraining bolt (7) keeps the armature plate from rotating, but the plate moves axially by electromagnetic attraction and the tension of the pressure spring (17). The brake lining (8) is fitted to the hub (10), which is secured to the motor shaft with a key. The solenoid coil (18) is energized via a rectifier located within the terminal box.

Fig. 18 FB-1B, -2B, -3B Models

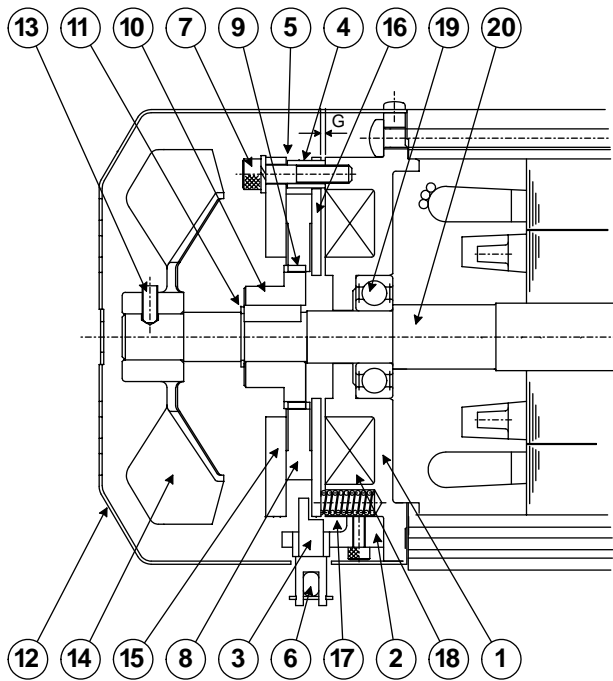


Table 13 FB-1B, -2B, -3B Parts

No.	Part Name	No.	Part Name
1	Stationary Core*	11	Retaining Ring
2	Brake Release Support	12	Fan Cover
3	Shifting Pin	13	Fan Set Pin
4	Spacer*	14	Fan
5	GAP Adjusting Sleeve*	15	Brake Shoe*
6	Brake Release Lever	16	Armature*
7	Restraining Bolt*	17	Pressure Spring*
8	Brake Lining*	18	Solenoid Coil*
9	Leaf Spring*	19	Fan Side Bearing
10	Hub*	20	Motor Shaft

\*These parts are included in a complete brake kit.

### b. Operating Principles

The brake is a (fail-safe type) spring actuated type brake that releases the brake mechanism when the solenoid coil is energized and engages when the solenoid coil is not energized.

When power is applied to the unit, the solenoid coil and electric motor become energized and the energized coil attracts the armature plate (16) against the tension of the pressure spring (17). As a result, the brake lining (8) disengages and the motor starts to run.

When the power is disconnected, the solenoid coil and electric motor are not energized. This causes the pressure spring (17) to actuate the armature plate (16), which in turn presses the brake lining (8) against the brakeshoe (15) and brings the motor to a quick stop.

## 3. Inspection

a. At regular intervals, check that:

- the unit is operating normally.
- the brake lining is not excessively worn (or gap G is normal).
- all the mounting screws are securely tightened.

b. Manual brake release procedure

FB-1B, -2B, -3B brakemotors are equipped with a one-touch release mechanism. To manually release the brake with power to the unit turned off, pull the brake release lever out from its holder and push it forward toward the reducer. Releasing the lever will re-engage the brake.

## 4. Gap Inspection

The brake lining will wear after the unit has been used for a long period of time. Regularly check that gap G (Fig. 18) is at an acceptable value. If gap G becomes too large, the solenoid coil may fail to pull in the armature plate, and hence cannot release the brake, resulting in the unit remaining in a continuously braked condition. Follow these steps to inspect the brake gap:

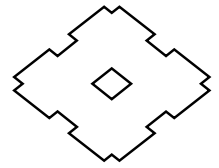
a. Remove the cover (12).

b. Insert a gap gage into the space between the stationary core (1) and armature plate (16). Measure the gap size at three appropriate circumferential points.

c. The gap needs to be adjusted if the values are close to the allowable limit listed in Table 14.

Table 14 Brake Gap Size

Brake Type	Gap value G (in)	
	Spec. value	Allowable limit
FB-1B	0.008 ~ 0.012	0.020
FB-2B	0.008 ~ 0.012	0.020
FB-3B	0.008 ~ 0.012	0.028



## 5. Gap Adjustment

If the brake lining is so heavily worn that gap adjustment is required, follow these steps:

- a. Remove the cover (12). Measure the gap size to confirm the deviation from the specification value. The minimum adjustable setting is no less than the thickness of the Gap adjusting shim, 0.008 in.
- b. Loosen the set pin (13) and remove the fan (14).
- c. Slightly loosen the restraining bolt (7) and remove parts (4), (5), (7) and (15) as a set. Be careful not to remove only the bolt (7) and lose the shims (5).
- d. One gap adjusting shim (5) is 0.008 in. thick. Decrease the number of shims in use according to the degree of wear (**Note: Retain the removed shims for use during the brake lining replacement procedure**). Reassemble parts (4), (5), (7) and (15) as a set.
- e. Once reassembled, check gap G. If the gap size is still too large, adjust the number of shims again.
- f. After completing the gap adjustment, turn the system power on and off a few times to check the brake performance.
- g. Replace the fan (14), set pin (13) and cover (12).

## 6. Brake Lining Replacement

Follow these steps to replace the brake lining when its thickness has reached the allowable limit shown in Table 15, or when sleeve adjustment is no longer an effective means of gap adjustment:

- a. Remove the cover (12) and measure the gap G. Remove the set pin (13) and the fan (14).
- b. Slightly loosen the restraining bolt (7) and remove parts (4), (5), (7) and (15) as a set.
- c. Remove the brake lining (8), taking care to prevent the leaf spring from coming off.
- d. Install the new brake lining, taking care not to damage or remove the leaf spring (9). Ensure that the lining moves smoothly along the hub (10).
- e. Replace any gap adjusting shims removed and retained from previous gap adjustments. Then reinstall parts (4), (5), (7) and 15 as a set.
- f. Measure gap G. Readjust if the gap is not within the specification value range.
- g. Turn the system power on and off a few times to check the brake performance. If no abnormalities are detected, replace the fan (14), set pin (13) and cover (12).

**Table 15 Brake Lining Size**

Brake Type	Brake lining dimension	Initial thickness $t_0$ (in)	Allowable thickness limit $t_0$ (in)
FB-1B		0.276	0.236
FB-2B		0.322	0.283
FB-3B		0.354	0.315

## Brake Models FB-5B and FB-8B

### 1. Standard Brakemotor Specifications

Table 16 lists the standard specifications for Models FB-5B and FB-8B.

**Table 16 Models FB-5B, FB-8B Standard Specifications**

Brake Type	Motor HP	Brake Torque ft-lb	Inertia $WK^2$ lb-ft <sup>2</sup>	Brake Coil	Brake Current (A)		Coil Resis ohms	Brake Delay Time (seconds)	
					230V	460V		Normal	Fast
FB-5B	5	27	0.0227	DC Energized Type, Built-in Rectifier within Conduit Box	0.7	0.3	308	0.4 ~ 0.5	0.01 ~ 0.02
FB-8B	7.5	40	0.0297		0.7	0.3	308	0.3 ~ 0.4	0.01 ~ 0.02

Notes: 1) Continuous time rating for both the brake and motor.  
2) Indoor types can be installed for use in any orientation.

# FB BRAKE ASSEMBLY – INSPECTION, ADJUSTMENT & MAINTENANCE

## 2. Construction and Operating Principles

### a. Construction

Fig. 19 illustrates the construction of the brake. Among the brake parts, the stationary core (1), solenoid coil (18), and stud bolt (3) constitute an integral subassembly unit. The stud bolt (3) keeps the armature plate (16) from rotating, but the plate moves axially by electromagnetic attraction and the tension of the pressure spring (17). The adjusting washer (4) and spring washer (7) hold the brake shoe (15) against the nut (8) at all times. The brake lining (9) is fit to the hub (10), which is secured to the motor shaft with a key.

Fig. 19 FB-5B, FB-8B Models

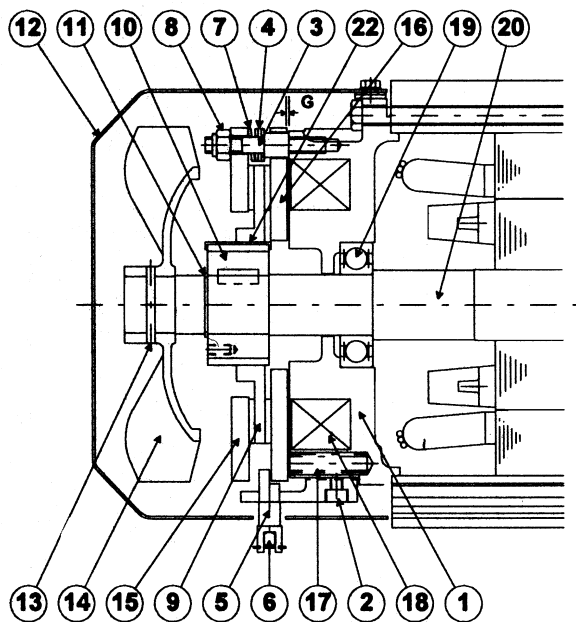


Table 17 FB-5B, -8B Parts

No.	Part Name	No.	Part Name
1	Stationary Core*	12	Fan Cover
2	Brake Release Support	13	Fan Set Screw or Pin
3	Stud Bolt*	14	Fan
4	GAP Adjusting Washer*	15	Brake Shoe*
5	Shifting Pin	16	Armature*
6	Brake Release Lever	17	Pressure Spring*
7	Spring Washer*	18	Solenoid Coil*
8	Nut*	19	Fan Side Bearing
9	Brake Lining*	20	Motor Shaft
10	Hub*	21	Bearing Cover
11	Retaining Ring	22	Leaf Spring*

\*These parts are included in a complete brake kit.

### b. Operating Principles

The brake is a (fail-safe type) spring actuated type brake that releases the brake mechanism when the solenoid coil is energized and engages when the solenoid coil is not energized.

When power is applied to the unit, the solenoid coil and electric motor become energized and the energized coil attracts the armature plate (16) against the tension of the pressure spring (17). As a result, the brake lining (9) disengages and the motor starts to run.

When the power is disconnected, the solenoid coil and electric motor are not energized. This causes the pressure spring (17) to actuate the armature plate (16), which in turn presses the brake lining (9) against the brakeshoe (15) and brings the motor to a quick stop.

## 3. Inspection

- At regular intervals, check that:
  - the unit is operating normally.
  - the brake lining is not excessively worn (or gap G is normal).
  - all the mounting screws are securely tightened.
- Manual brake release procedure  
 FB-5B, -8B brakemotors are equipped with a one-touch release mechanism. To manually release the brake with power to the unit turned off, pull the brake release lever out from its holder and push it forward toward the reducer. Releasing the lever will re-engage the brake.

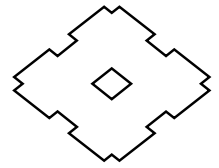
## 4. Gap Inspection

The brake lining will wear after the unit has been used for a long period of time. Regularly check that gap G (Fig. 18) is at an acceptable value. If gap G becomes too large, the solenoid coil may fail to pull in the armature plate, and hence cannot release the brake, resulting in the unit remaining in a continuously braked condition. Follow these steps to inspect the brake gap:

- Remove the cover (12).
- Insert a gap gage into the space between the stationary core (1) and armature plate (16). Measure the gap size at three appropriate circumferential points.
- The gap needs to be adjusted if the values are close to the allowable limit listed in Table 18.

Table 18 Brake Gap Size

Brake Type	Gap value G (in)	
	Spec. value	Allowable limit
FB-5B	0.016 ~ 0.020	0.039
FB-8B	0.016 ~ 0.020	0.039





## 5. Gap Adjustment

If the brake lining is so heavily worn that gap adjustment is required, follow these steps:

- a. Remove the cover (12).
- b. Insert a gap gage into the space between the stationary core (1) and the armature plate (16) and rotate the nut (8) at the tip of the stud bolt (3) clockwise until the gap measures an appropriate size. If the gap is too large to adjust by this procedure, decrease the number of adjusting washers (4) in use. Evenly adjust the three nuts (8) until the gaps at the three circumferential points are equal and fall within the specification range shown in Table 18.
- c. After completing the gap adjustment, turn the system power on and off a few times to check the brake performance.
- d. Replace the fan (14), set pin or screw (13) and cover (12).

**Table 19 Brake Lining Size**

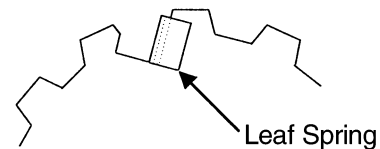
Brake Type	Brake lining dimension	Initial thickness $t_0$ (in)	Allowable thickness limit $t_0$ (in)
FB-5B		0.394	0.237
FB-8B		0.394	0.237

## 6. Brake Lining Replacement

Follow these steps to replace the brake lining when its thickness has reached the allowable limit shown in Table 19, or when sleeve adjustment is no longer an effective means of gap adjustment:

- a. Remove the cover (12), set pin (13) and fan (14).
- b. Remove all three nuts (8)
- c. Remove the brake shoe (15) and take out the brake lining (9).
- d. Fix the leaf spring (22) as shown in Fig. 20.
- e. Apply a small amount of grease along the spline of the new brake lining (9), taking care not to apply any to the wear surface.
- f. Fit the new brake lining (9) onto the hub (10) and check that it moves smoothly. Remove any excess grease.
- g. After reassembling the brake, measure gap G. If the gap is out of the specification range, adjust by rotating the gap adjusting nut (8).
- h. Turn the system power on and off a few times to check the brake performance. If no abnormalities are detected, replace the fan (14), set pin (13) and cover (12).

**Fig. 20 Leaf Spring**



# TROUBLESHOOTING

The SM-Hyponic is running normally when it meets the following criteria:

1. The motor begins to run immediately after the start switch is moved to the ON position.
2. The unit does not make any abnormal sounds during operation.
3. The motor stops running within about 0.5 seconds after power to the unit is switched off.

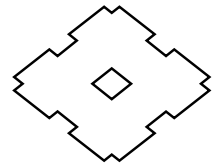
If you find any abnormality, refer to Table 20 Quick Troubleshooting Guide on pages 14 – 15, and take the appropriate corrective action as soon as possible.

# TROUBLESHOOTING

**Table 20 Quick Troubleshooting Guide**

Problem		Possible Cause		Corrective Action
SM-HYPONIC	Runs Hot	Overloading	Load exceeds the capacity of the SM-Hyponic	Check rated capacity of the SM-Hyponic; replace with unit of sufficient capacity or reduce load.
		Improper lubrication	Insufficient lubrication	Check lubricant level and increase to recommended level.
			Excessive lubrication	Check lubricant level and reduce to recommended level.
	Vibration or noise	Loose Foundation bolts	Weak mounting structure	Inspect mounting of SM-Hyponic. Tighten loose bolts and/or reinforce mounting structure.
			Loose bolts	Tighten bolts.
		Failure of bearings	May be due to lack of lubricant	Replace bearing(s). Clean and flush SM-Hyponic; fill with recommended lubricant.
			Overload	Check rated capacity of SM-Hyponic, replace with unit of sufficient capacity or reduce load.
		Insufficient lubricant	Level of lubricant in the SM-Hyponic not properly maintained	Check lubricant level and adjust to factory recommended level.
	Output shaft does not turn	Motor shaft broken	Overloading of reducer can cause damage	Replace broken shaft. Check rated capacity of SM-Hyponic.
			Key missing or sheared off on input shaft	Replace key.
Motor doesn't turn		Motor	Refer to Motor section of Troubleshooting Guide.	
MOTOR	Load is disconnected but motor doesn't rotate	Makes a groaning sound	Faulty switch contact	Adjust the contact.
			Blown fuse	Replace.
			One phase wire of the power supply open	Replace.
			Stator coil open	Repair by rewinding or replacing stator assembly.
			Stator and rotor touching due to bearing housing wear	Replace the bearing and bracket.
	Doesn't make any noise	Outside the motor	Three phase is operating as single-phase	Check the power source with a voltmeter.
			Stator coil open	Repair by rewinding or replacing stator assembly.
			Power failure Open connection wire Faulty switch contact Faulty starter contact	Contact the power company. Check the source wiring. Adjust the contact.
	Rotates with the load disconnected, but:	Rotates in the wrong direction	Connection error	Change any two of the three-phase source.
		Fuse blows	Shorted lead wire	Replace.
Speed doesn't increase		Faulty starter contact	Adjust.	





**Table 20 Quick Troubleshooting Guide (cont.)**

Problem		Possible Cause		Corrective Action	
MOTOR (cont.)	Rotates with the load disconnected, but: (cont.)	Groans	Overcurrent Overheating	Rotor and stator touching	Repair by winding or replacing stator assembly.
			Overcurrent	One phase of stator coil shorted	Replace the stator winding.
		Makes a high pitched metallic noise	Faulty bearing		Replace the bearing.
	Rotates when the load is disconnected but when the load is connected:	Switch overheats	Insufficient switch capacity		Replace with one having the rated capacity.
			Overload		Drop to the rated load.
		Fuse blows	Insufficient fuse capacity		Replace with one having the rated capacity.
		Overheats	Overload		Drop to the rated load.
			Voltage drop		Consult with the power company.
		Speed suddenly drops	Voltage drop		Consult with the power company.
			Overload		Drop to the rated load.
Stops	Bearing damaged by overheat		Replace the bearing.		
BRAKE	Brake fails to operate		Improper adjustment after reassembly		Adjust again.
	Brake slips (Braking time is too long)		Not wired for fast action		Wire for fast action.
			Foreign matter entrapped in brake lining. Oil on lining surface		Remove foreign matter and take preventive action. Wipe lining surface with a dry cloth.
			Worn brake lining		Adjust brake gap or replace lining.
			Uneven brake gap		Adjust evenly.
			Excessive load		Decrease load or use larger brake.
	Rotor fails to turn		Faulty electric circuit		Check circuit.
			Blow fuse		Replace fuse.
			Only single phase available from three phase power supply		Measure power supply voltage and check for defective circuit.
			Protective device has tripped		Eliminate cause and reset.
			Damaged or burned motor winding		Repair or replace.
			Rust on brake friction surface		Clean brake (lining).
			Gap needs adjustment		Readjust gap.
			Burned bearing		Replace.
	Overload		Check and troubleshoot load and safety device.		
	Abnormal noise		Foreign material inside the brakemotor.		Examine inside brakemotor and remove foreign material.
			Damaged bearing		Replace.
			Worn brake lining		Adjust brake gap or replace lining.
			Hub leaf spring is off or damaged		Replace.
			Burned solenoid coil		Replace.
Damaged rectifier			Replace.		
Trouble under loaded condition		Voltage drop		Raise voltage to rated level.	
		Overload		Reduce the load or oversize the brakemotor.	
		Improper protective device setting		Adjust protective device.	

# CONSTRUCTION

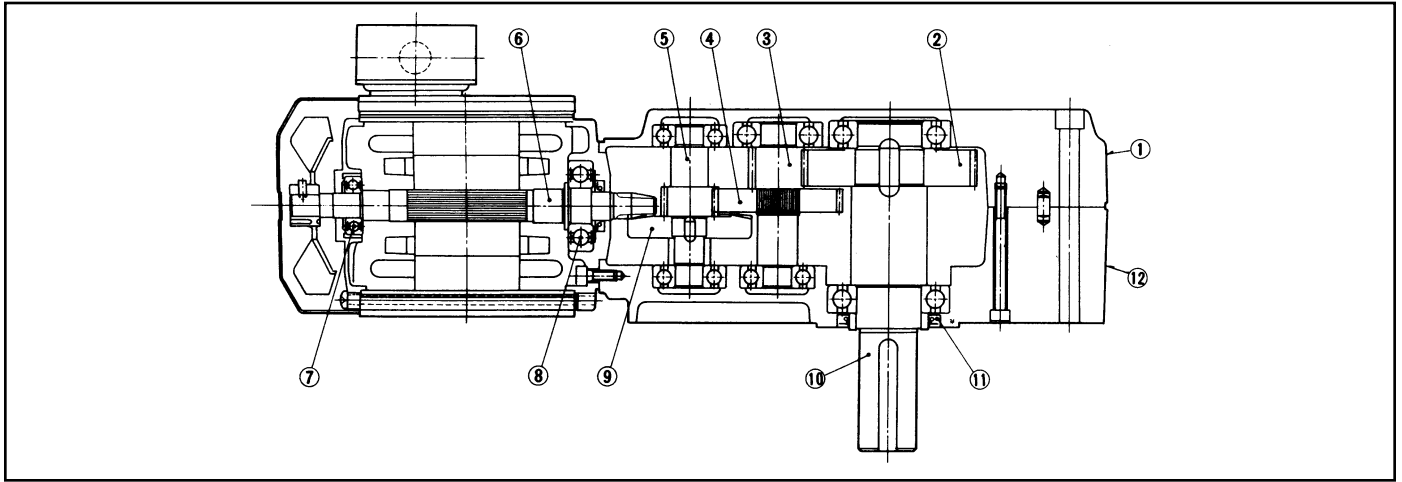


Fig. 21 RNFM series

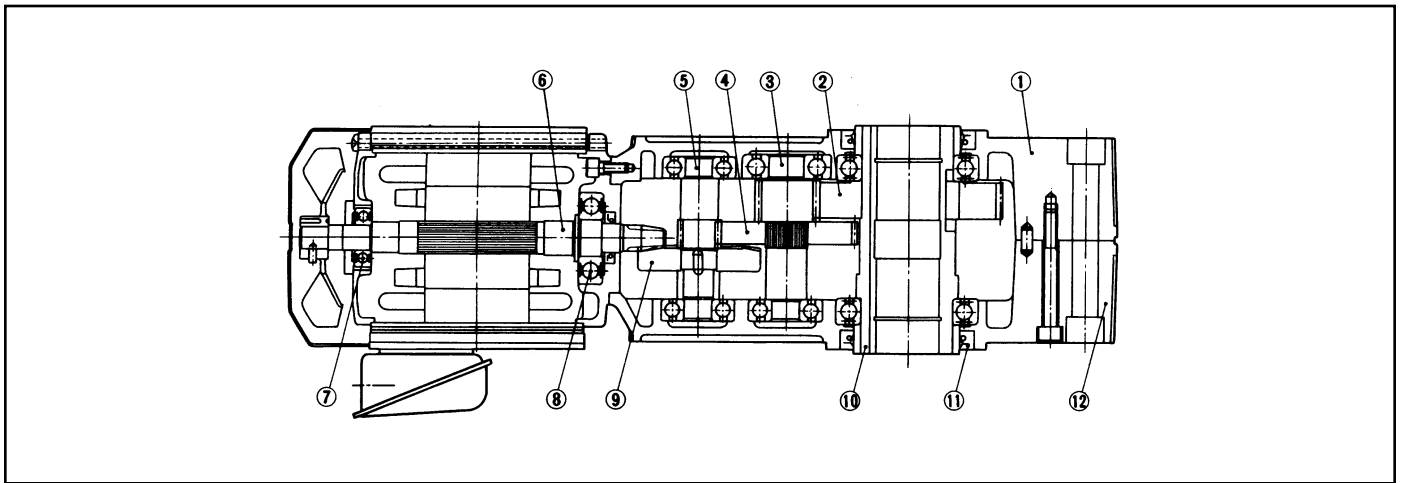


Fig. 22 RNYM series

Table 21 Main Parts

Part No.	Description
1	Case (1)
2	Gear
3	Pinion shaft
4	Gear
5	Pinion shaft
6	Hypoid pinion shaft
7	Bearing metal
8	Bearing metal
9	Hypoid gear
10	Output shaft
11	Oil seal
12	Case (2)



### Headquarters and Manufacturing

Sumitomo Machinery Corporation of America  
 4200 Holland Boulevard, Chesapeake, VA 23323  
 (757) 485-3355 • FAX: (757) 485-3075  
 Toll Free: 1-800-SM-CYCLO (762-9256)  
 www.smcyclo.com • e-mail: smcamktg@series2000.com



### North American Regional Offices Stocking & Assembly Facilities

#### Mid-West

Sumitomo Machinery Corporation of America  
 175 West Lake Drive  
 Glendale Heights, IL 60139  
 (630) 752-0200 • FAX: (630) 752-0208

#### West

Sumitomo Machinery Corporation of America  
 2375 Railroad Street  
 Corona, CA 91720  
 (909) 340-4100 • FAX: (909) 340-4108

#### Southwest

Sumitomo Machinery Corporation of America  
 1420 Halsey Way #130  
 Carrollton, TX 75007  
 (972) 323-9600 • FAX: (972) 323-9308

#### Southeast

Sumitomo Machinery Corporation of America  
 4200 Holland Boulevard  
 Chesapeake, VA 23323  
 (757) 485-3355 • FAX: (757) 487-3193

### Canadian Stocking & Assembly Facilities

**Toronto (East)**  
 SM-Cyclo of Canada, Ltd.  
 870 A Equestrian Court  
 Oakville, Ontario, Canada L6L 6L7  
 (905) 469-1050 • FAX: (905) 469-1055

**British Columbia (West)**  
 SM-Cyclo of Canada, Ltd.  
 740 Chester Road, Annacis Island, Delta  
 B.C., Canada V3M 6J1  
 (604) 525-5403 • FAX: (604) 525-0879

**Montreal**  
 SM-Cyclo of Canada, Ltd.  
 226 Migneron Street  
 St. Laurent, Quebec, Canada H4T 1Y7  
 (514) 340-1300 • FAX: (514) 340-1343

### Mexico

**Monterrey**  
 SM-Cyclo de Mexico, S.A. de C.V.  
 Calle "C" No. 506A  
 Parque Industrial Almacentro  
 Apodaca, N.L., Mexico 66600  
 Tel.: 011-52-8-369-3697/8 • FAX: 011-52-8-369-3699

### Central & South America Sales, Engineering, Stocking & Assembly

**Brazil**  
 SM-Cyclo Redutores do Brasil Ltda.  
 Av. Dr. Ulysses Guimarães, 3533  
 09990-080 Diadema  
 São Paulo, Brazil  
 Tel.: 011-55-11-445-4388 • FAX: 011-55-11-456-2922

**Chile**  
 SM-Cyclo de Chile Ltda.  
 Avenida Zanartu #1231  
 Comuna Nunoa - Santiago, Chile  
 Tel.: 011-562-237-2407 • FAX: 011-562-237-0225

### Other International Locations

**Japan**  
 Sumitomo Heavy Industries  
 Power Transmission & Controls Group  
 5-9-11, KITA-Shingawa Shinagawa-Ku  
 Tokyo 141-8686 Japan  
 Tel.: 011-813-5488-8363 • FAX: 011-813-5488-8355

**United Kingdom**  
 Sumitomo (SHI) Cyclo Drive Europe  
 Marfleet, Kingston upon Hull  
 HU9 5RA, United Kingdom  
 Tel.: 011-44-1482-788022 • FAX: 011-44-1482-713205

**Southeast Asia**  
 Sumitomo (SHI) Cyclo Drive Southeast Asia  
 No. 2 Tuas Link 2  
 Singapore 638551  
 Tel.: 011-65-863-2238 • FAX: 011-65-863-4238

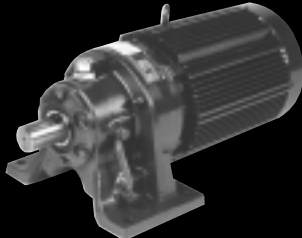


**SPEED REDUCER**



**SM-CYCLO**  
Concentric

**GEARMOTOR**



**SM-CYCLO**  
Concentric

**SHAFT MOUNTED  
GEARMOTOR**



**SM-HELICAL BUDDYBOX**  
Parallel Offset

**BEVEL GEAR MOTOR**



**SM-BEVEL BUDDYBOX**  
Right Angle

**LOW RATIO PLANETARY**



**SM-CYCLO**  
Concentric

**PRECISION CYCLO**



Concentric

# SUMITOMO

## "QuaDelta" PROGRAM

Providing

THE AVAILABLE SOLUTION, WORLDWIDE



- ▲ GEAR BOXES
- ▲ MOTORS
- ▲ CONTROLLERS



- ▲ CONCENTRIC
- ▲ PARALLEL OFFSET
- ▲ RIGHT ANGLE



- ▲ CONSTANT SPEED
- ▲ MECHANICAL VS
- ▲ ELECTRICAL VS



- ▲ THE AMERICAS
- ▲ ASIA
- ▲ EUROPE

**MECHANICAL  
VARIABLE SPEED**



**SM-BEIER**

**ELECTRICAL  
VARIABLE SPEED**



**AF-3100x** AC Drive    **NTAC-2000** AC Drive

**HELICAL  
GEAR REDUCER**



**PARAMAX**  
Parallel Offset  
& Right Angle

**SHAFT MOUNT  
SPEED REDUCER**



**SM-SHAFT MOUNT**  
Parallel Offset

### SUMITOMO MACHINERY CORP. OF AMERICA

#### Power Transmission Products

4200 Holland Blvd., Chesapeake, VA 23323  
(757) 485-3355 • FAX: (757) 485-3075

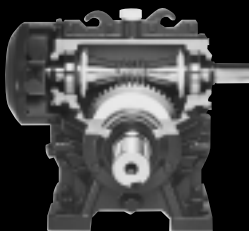
Toll Free: 1-800-SM-CYCLO

Web: <http://www.smcyclo.com> • E-mail: [smcamktg@series2000.com](mailto:smcamktg@series2000.com)

DISTRIBUTED BY:



**DOUBLE ENVELOPING  
WORM GEAR**



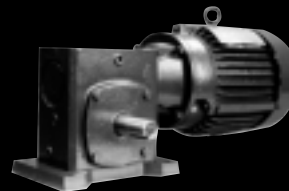
**SM-HEDCON**  
Right Angle

**SHAFT MOUNT  
GEARMOTOR**



**SM-HYPONIC**  
Right Angle

**WORM GEAR MOTOR**



**SM-ULYSSES**  
Right Angle

**PARTS & SERVICE**



WORLDWIDE